



 **COOLON**

BRN

70W Batten Light

The BRN LED Light is the most indestructible batten luminaire available in the market.

Designed specifically for the harsh conditions of the mining industry, the BRN is ready to withstand any hazards present on a site. This robust fitting features a scratch-proof series 6000 powder-coated aluminium body, a polyurethane encapsulation technology, complete input surge protection and high ratings of IP66 and IK09. Severe impacts, water/dust penetration, hot temperatures, and insects – nothing will interrupt the reliable performance of the BRN.

Providing an exceptional power of 70W at 230VAC input voltage, the BRN offers uninterrupted high-quality light, efficient energy consumption, high Colour Rendering Index and no stroboscopic effect.

The BRN doesn't simply live up to the Coolon LED batten luminaire heritage – it exceeds it.

Designed for use in:

- Workshops
- Switchboard / Switchroom
- Pump Rooms
- Carparks
- Walkways
- Stairwells

 **DESIGNED &
MANUFACTURED
IN AUSTRALIA**



High Lumen Output

Providing double the light of an average LED batten, the BRN offers high lumen output, energy efficiency and no stroboscopic effect.



Built to Last

BRN is specifically designed to withstand harsh conditions of an industrial site. Equipped with a powder-coated aluminium body, input surge protection and IP66 rating, the expected lifespan is 50,000 hours at 75% brightness.



COOL SURFACE TEMPERATURE

Coolon's Industrial LED fittings have a much lower surface temperature than traditional HID equivalents which prevents dirt from baking onto the luminaire. This allows for easier cleaning and will prolong the lifespan of the luminaire.



INSTANT ON/OFF

LEDs do not require warm up. Instant on to 100% output translates to no downtime, improved safety and the ability to utilize sensor switching to significantly save energy.



NO FLICKERING

LED luminaires run on constant low voltage DC power and do not produce any visible stroboscopic effects, thus reducing the strain on eyes and significantly improving safety in areas where moving machinery is present.

IP66

HIGH IP RATING - IP66

Coolon's Industrial LEDs are designed specifically to withstand the harsh conditions in mining environments. The robust design allows our LED products to be used in many different applications and are high pressure washable.



LOW SUSCEPTIBILITY TO VIBRATION

This luminaire is designed to handle continuous exposure to vibration. A typically critical issue affecting the life and operation of most common gas discharge lamp based light sources is mechanical shock and vibration.

L70

LONG USEFUL OPERATING LIFE

At Coolon we believe the lifetime of a luminaire is so much more than just the LED's. Coolon product lifetime takes the entire luminaire into consideration and each product is backed by a comprehensive warranty – that's the Coolon confidence.

5
YEARS

5 YEARS FACTORY WARRANTY

Coolon luminaires are covered by a solid comprehensive manufacturer's warranty that covers a range of possible defects and performance parameters throughout the duration of the warranty period.



DESIGNED AND BUILT FOR AUSTRALIAN CONDITIONS

Engineered to perfection, using only the highest quality components and highly skilled labour, each luminaire is assembled and thoroughly tested to ensure that it exceeds the highest standards.

DIMENSIONS

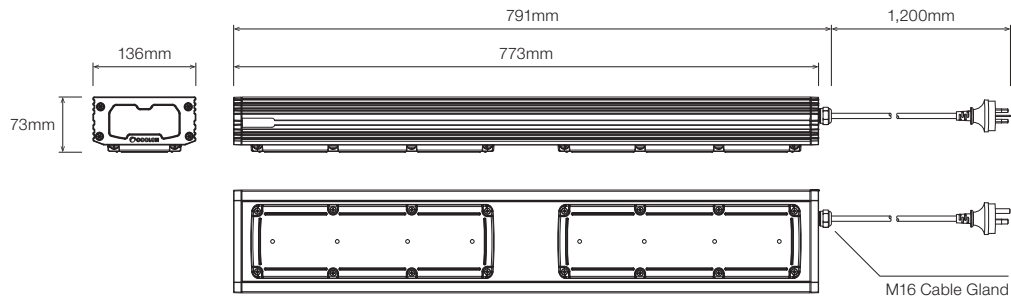

MOUNTING BRACKET

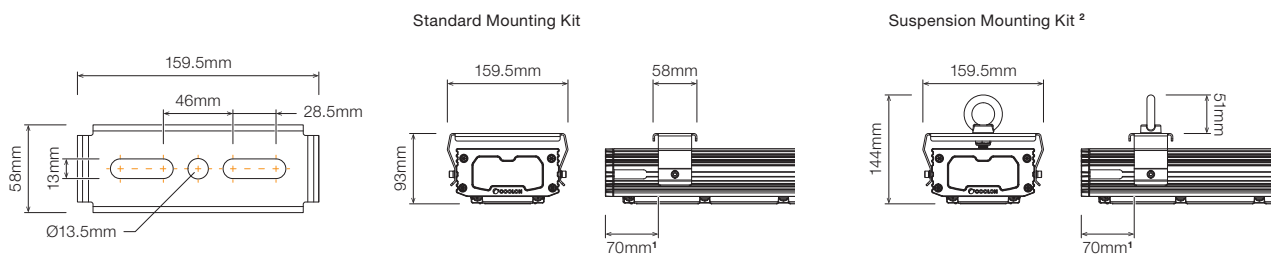

¹Note: Recommended minimum distance from endcap (both sides)

²Note: Lanyard / chain not provided by Coolon

TECHNICAL SPECIFICATIONS

Product	BRN Batten Light
Model	BRN
Optical Characteristics	
Luminous Flux (Photometered)	8,567 lm
CCT	NWT
CRI	>70
Electrical Characteristics (Luminaire)	
Power Consumption	70W @230VAC
Nominal Voltage	230VAC
Voltage Range	90 – 305VAC / 127 – 250VDC
Power Factor (PF)	>0.9 @ 120 – 240VAC, 50 – 60Hz
Input Surge Protection	4kV line-line, 6kV line-earth
Inrush Current (I _{rt}) ¹	0.26 A ² s @ 220VAC, 25° cold start
Total Harmonic Distortion (THD)	10% @ 120-240VAC, 50-60Hz
Leakage Current	0.70mA @ 240VAC, 60Hz
Cable Characteristics	
Cable Type	Standard 3 core flex with molded 3 pin AU plug
Cable Length	1200mm
Cable Diameter	7.5mm

Environmental	
IP Rating	IP66
Impact Rating	IK09
Operating Temp. Range	-20 to +50°C
Expected Lifespan	50,000 Hours to 70% Brightness
Material Composition (Body)	AL 6000 Series, Polyester Powder Coated
Material Composition (Cover)	PC
Material Composition (Bracket)	Stainless Steel
Mounting / Bracket Type	Surface Mount / Hook Mount

Weight/Packaging	
Luminaire Weight	6kg
Packaging Dimensions	865 x 170 x 95mm

Warranty	
Warranty	5 years warranty as standard

¹Note: At 220Vac input, 25° cold start, duration=236µs, 10%Ipk-10%Ipk. See Inrush Current Waveform for the details.

Reading taken while test unit operating in steady state. Ambient temperature during testing is typically 25°C. Individual unit behaviour may differ due to electronic component tolerance and ambient conditions. Product parameters and application suitability shall be checked by the user prior to commissioning.

COLOUR TEMPERATURES



All colour temperatures are indicative. Some variation can occur.

ILLUMINANCE AT DISTANCE

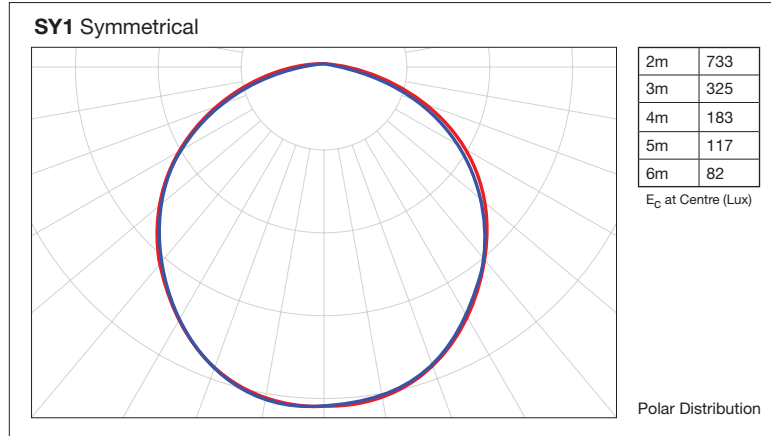

INRUSH CURRENT WAVEFORM

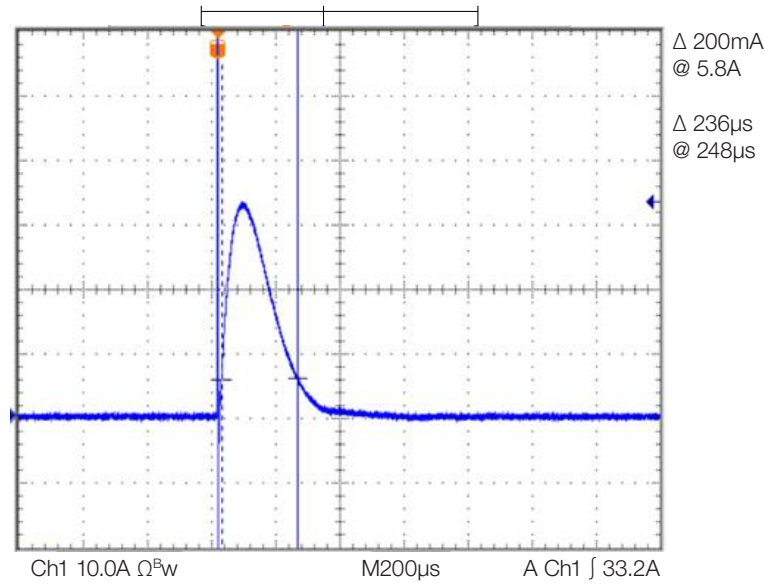

ORDERING EXAMPLE

BRN - 70 - NWT - SY1 - MP

PRODUCT TYPE COLOUR TEMPERATURE OPTICS SUPPLY OPTION

PRODUCT	TYPE	COLOUR TEMPERATURE	OPTICS	SUPPLY OPTION
BRN	70 70W	NWT Neutral White	SY1 Symmetrical / Diffuser	MP Mains Powered